

1800°F / 982°C: DuctSeal™
Kitchen Grease Duct Gasket Seal Slit Tape
Extreme High Temperature, Heat, Flame & Fire Resistant



Highly flexible and minimal shrinkage. High abrasion resistance and tensile strength. Melts above 3000°F / 1648°C. Available with a PSA (pressure sensitive adhesive) to facilitate easy installation (*see note).

Can be used at 1800°F / 982°C continuously with excursions to 3000°F / 1650°C.

Weave is tight, but edge fray is possible with slit tapes. For non fray edges use a woven tape.

WILL NOT BURN

| DuctSeal™ InSilMax™ Extreme Temperature, Heat, Flame Resistant Slit Tapes | | | | | |
|--|-------------------------------------|-----|-----|--|----------|
| 0.090" / 2.3mm Thick Tape | | | | | |
| Part Number | Width inch / mm / dash # | | | Price per foot / Metre 25 & 50 foot Standard Roll | |
| ISST-M025-16 | 1" | 25 | -16 | \$ 1.32 | \$ 4.33 |
| ISST-M032-20 | 1 1/4" | 32 | -20 | \$ 1.52 | \$ 4.98 |
| ISST-M038-24 | 1 1/2" | 38 | -24 | \$ 1.68 | \$ 5.51 |
| ISST-M051-32 | 2" | 51 | -32 | \$ 2.04 | \$ 6.69 |
| ISST-M064-40 | 2 1/2" | 64 | -40 | \$ 3.08 | \$ 10.10 |
| ISST-M076-48 | 3" | 76 | -48 | \$ 3.72 | \$ 12.20 |
| ISST-M102-64 | 4" | 102 | -64 | \$ 4.98 | \$ 16.33 |
| ISST-M127-80 | 5" | 127 | -80 | \$ 5.80 | \$ 19.02 |
| ISST-M152-96 | 6" | 152 | -96 | \$ 6.63 | \$ 21.75 |

Available in standard 25 foot / 7.6 metre or 50 foot / 15.2 metre rolls
For other lengths add +25% to price shown

* Note: The PSA will deteriorate at temperatures above 400°F and should be used to facilitate installation only. Material with PSA should not be used in confined areas at elevated temperatures without ventilation until all of the PSA has vaporized.

This Product is Available By-The-Foot / Metre

1800°F / 982°C: DuctSeal™

Folded & Stitched Tape for Commercial Kitchen Duct Gasket Seal

Extreme High Temperature, Heat, Flame Resistant



Highly flexible and minimal shrinkage. High abrasion resistance and tensile strength. Melts above 3000°F / 1648°C. Available with a PSA (pressure sensitive adhesive) to facilitate easy installation (*see note).

Can be used at 1800°F / 982°C continuously with excursions to 3000°F / 1650°C.

Folded & Stitched tape is a thicker alternative to Slit Tape. Top roll in photo is one layer slit tape; 2nd roll from top is 2 layer folded and stitched; 3rd roll from top is three layer folded and stitched and bottom roll is 4 layer folded and stitched. All tapes are same length.

WILL NOT BURN

| DuctSeal™ InSilMax™ Extreme Temperature, Heat, Flame Resistant Folded & Stitched Tapes | | | | | | |
|---|-----|------|------------------|---|--|---|
| Folded & Stitched Tape – 25 or 50 foot roll | | | | | | |
| Available in 3 thicknesses: 1/8" / 3.2mm thick • 3/16" / 4.8mm thick • 1/4" / 6.4mm thick | | | | | | |
| Width inch / mm / dash # | | | Part Number | 1/8" / 3.2mm Price / Foot x value = 2 | 3/16" / 4.8mm Price / Foot x value = 3 | 1/4" / 6.4mm Price / Foot x value = 4 |
| 1" | 25 | -16 | ISFST-M025-16-X | \$3.44 / \$11.28 | \$4.68 / \$15.35 | \$5.98 / \$19.61 |
| 1 1/4" | 32 | -20 | ISFST-M032-20-X | \$4.12 / \$13.51 | \$5.68 / \$18.63 | \$7.24 / \$23.74 |
| 1 1/2" | 38 | -24 | ISFST-M038-24-X | \$4.76 / \$15.61 | \$6.56 / \$21.52 | \$8.52 / \$27.95 |
| 2" | 51 | -32 | ISFST-M051-32-X | \$6.36 / \$20.86 | \$8.96 / \$29.39 | \$15.64 / \$51.30 |
| 2 1/2" | 64 | -40 | ISFST-M064-40-X | \$7.32 / \$24.01 | \$9.04 / \$29.65 | \$14.72 / \$48.28 |
| 3" | 76 | -48 | ISFST-M076-48-X | \$8.56 / \$28.08 | \$12.36 / \$40.54 | \$16.12 / \$52.87 |
| 4" | 102 | -64 | ISFST-M102-64-X | \$11.04 / \$36.21 | \$16.12 / \$52.87 | \$23.60 / \$77.41 |
| 5" | 127 | -80 | ISFST-M127-80-X | \$13.64 / \$44.74 | \$19.97 / \$65.50 | \$26.32 / \$86.33 |
| 6" | 152 | -96 | ISFST-M152-96-X | \$16.12 / \$52.87 | \$23.76 / \$77.93 | \$31.32 / \$102.73 |
| 8" | 203 | -102 | ISFST-M203-102-X | \$21.88 / \$71.77 | \$33.20 / \$108.90 | \$43.80 / \$143.66 |

For other than standard lengths, add 20% to the price shown

For the "X" value in the part number: specify "2" for 1/8" thick tape
"3" for 3/16" thick tape
"4" for 1/4" thick tape

Add "-P" to the part number to order tape with PSA on one side.

* Note: The PSA will deteriorate at temperatures above 400°F and should be used to facilitate installation only. Material with PSA should not be used in confined areas at elevated temperatures without ventilation until all of the PSA has vaporized.

1800°F / 982°C: DuctSeal™ Kitchen Duct Gasket Seal Tape

Extreme High Temperature, Heat, Flame, Resistant



Available in Plain and LadderTape™ (Drop Warp also known as Bolt-Hole Tape).

An alternative to asbestos and ceramic based textiles. Highly flexible and minimal shrinkage. High abrasion resistance and tensile strength. Melts above 3000°F / 1648°C. Available with a PSA (pressure sensitive adhesive) to facilitate easy installation (*see note).

Woven tape has the benefit over slit tape of edges that will not fray unless cut.

WILL NOT BURN

Other common applications for this tape are as a gasket and seal material on high temperature access doors, inspection and clean-out doors and panels for kilns, ovens, furnaces, ventilation systems, etc.

| DuctSeal™ InSilMax™ Extreme Temperature, Heat, Flame Resistant Woven Tapes | | | | | | |
|---|-----|-----|------------------|--|---|---|
| DuctSeal™ Plain & Drop Warp Woven Tape – 100 foot roll | | | | | | |
| Available in 3 thicknesses: 1/16" / 2mm thick • 1/8" / 3.2mm thick • 1/4" / 6.4mm thick | | | | | | |
| Width inch / mm / dash # | | | Part Number | 1/16" / 2mm Price per foot no PSA / with PSA | 1/8" / 3.2mm Price per foot no PSA / with PSA | 1/4" / 6.4mm Price per foot no PSA / with PSA |
| 1" | 25 | -16 | ISWT-M025-16-X-Z | \$ 1.36 / \$ 1.65 | \$ 3.09 / \$ 3.50 | \$ 3.88 / \$ 4.28 |
| 1 1/2" | 38 | -24 | ISWT-M038-24-X-Z | \$ 1.90 / \$ 2.33 | \$ 4.34 / \$ 4.94 | \$ 5.66 / \$ 6.26 |
| 2" | 51 | -32 | ISWT-M051-32-X-Z | \$ 2.47 / \$ 3.01 | \$ 5.74 / \$ 6.49 | \$ 7.45 / \$ 8.20 |
| 3" | 76 | -48 | ISWT-M076-48-X-Z | \$ 3.63 / \$ 4.60 | \$ 8.53 / \$ 9.83 | \$ 11.25 / \$ 12.55 |
| 4" | 102 | -64 | ISWT-M102-64-X-Z | \$ 4.65 / \$ 5.86 | \$ 11.48 / \$ 13.13 | \$ 15.02 / \$ 16.68 |

Same Price Plain or LadderTape™ (Drop Warp or Bolt-Hole Tape)

Some woven tapes available in 50 foot lengths – please enquire. Add 25% to above pricing when ordering in 50 foot lengths. Some tapes available in by-the-foot cut lengths – please enquire. Add 50% to above pricing when ordering by-the-foot cut lengths.

- For the "X" value, specify: "A1" for 1/16" thick tape "B2" for 1/8" thick tape "C4" for 1/4" thick tape
- For "Z" value in part number: use "-P" for Plain style tape or "-DW" for Drop Warp style tape.

Add "-PSA" to the part number to order tape with PSA on one side.

* Note: The PSA will deteriorate at temperatures above 400°F and should be used to facilitate installation only. Material with PSA should not be used in confined areas at elevated temperatures without ventilation until all of the PSA has vaporized.

DuctSeal™ Paste High Temperature Sealant:



DuctSeal™ Paste Duct Flange Sealant Paste

This sealant is used to form a bead ahead of the gasket tape in the flange area in order to keep grease from contaminating the tape.

Can be used to 500°F continuous without degradation.

In the event of a fire, the elevated temperatures will decompose the sealant, turning it into a white insulating powder through a process called caramelization.

During the fire, the gasket tape itself will maintain the seal in the flange. The sealant is available in Oxide-Red and Black.

Available in two sizes:

- 3 oz squeeze tube.
P/N DSP-03-OR \$16.61
- 10.3 oz caulking gun cartridge.
P/N DSP-10-OR \$37.47

DuctSeal™ Applications:

Apply a bead of sealant at this point around the perimeter of the duct/flange location

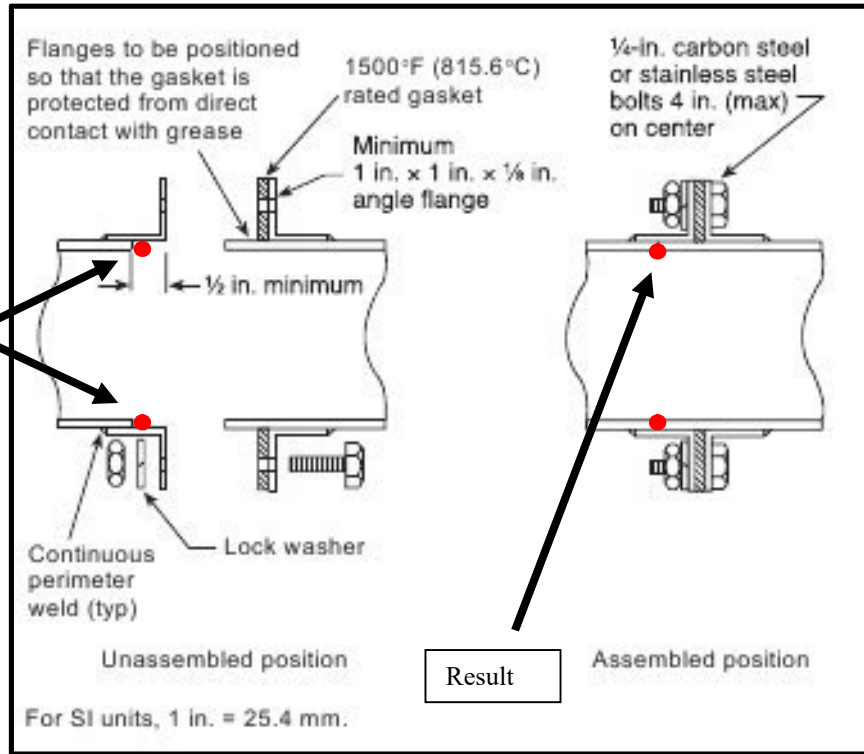

Apply a bead of sealant at this point around the perimeter of the duct/gasket location

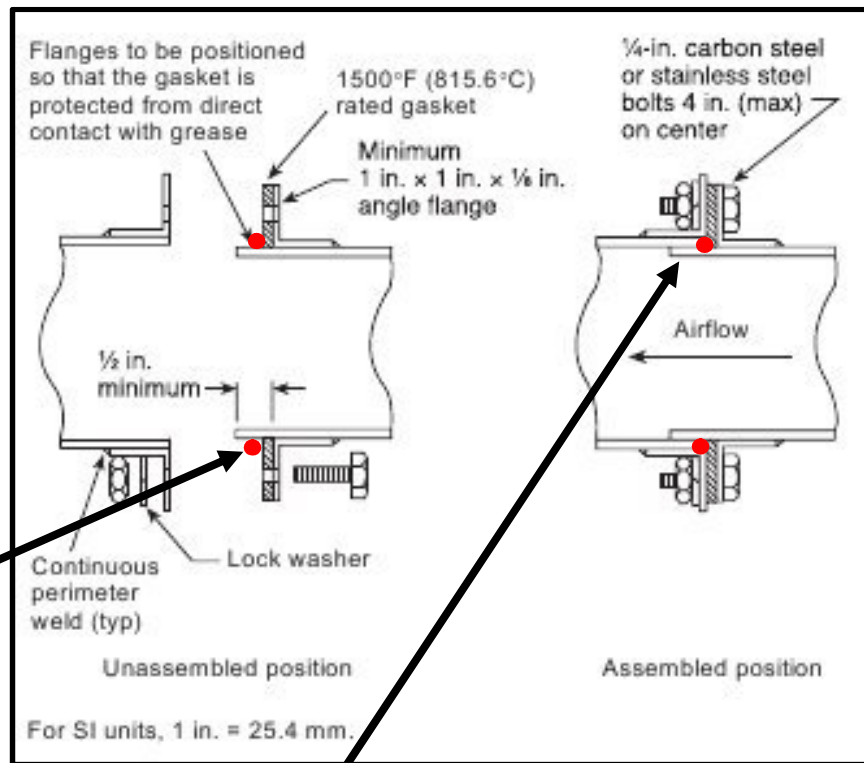

Result

Apply a bead of sealant at this point around the perimeter of the flange, at the base of the gasket.

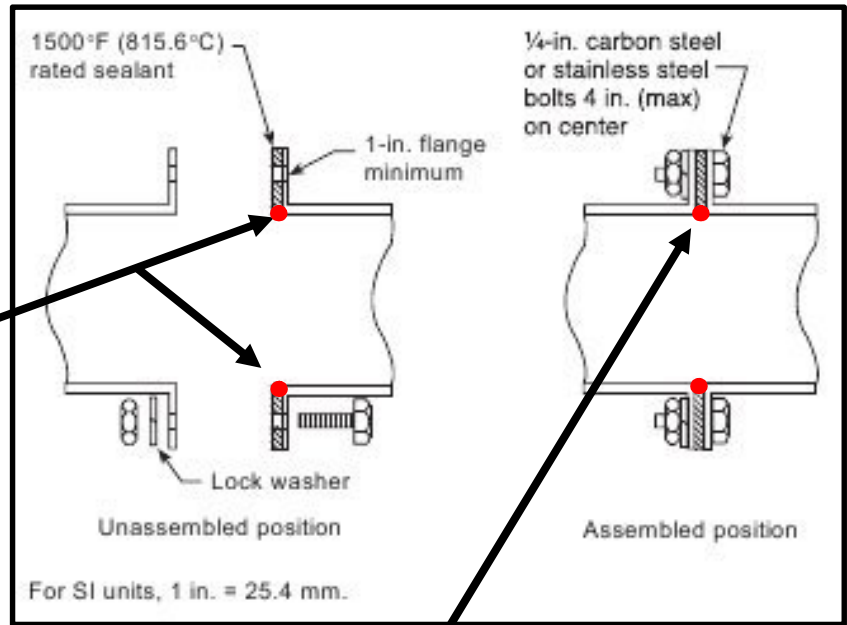

Result

Apply a bead of sealant at this point around the perimeter of the cone.

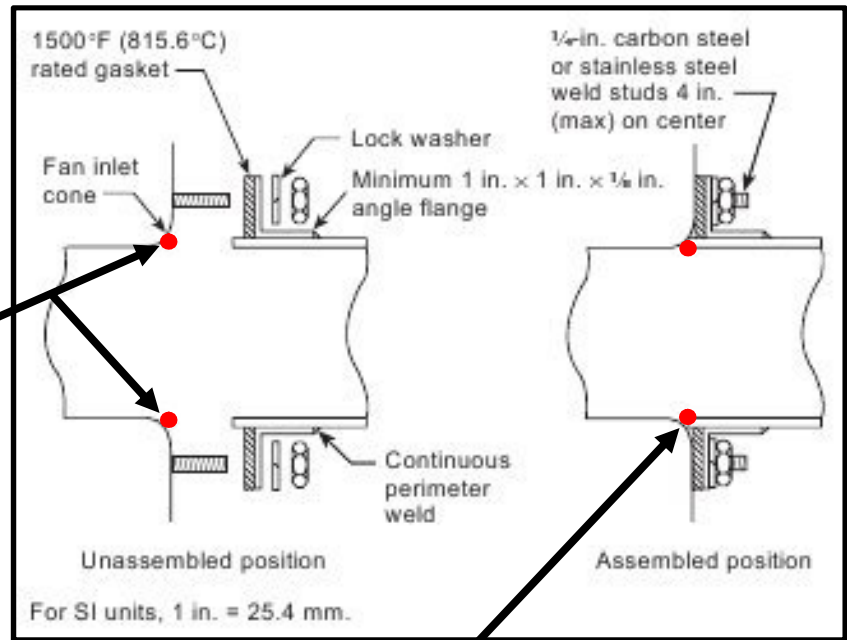

Result

DuctSeal™ Access Doors

- Heavy Duty 16 gauge steel construction
- Stainless Steel models available
- Available with extended studs to accommodate fire wrap
- Back frame reinforces duct cut-out
- Easy to clean and install
- Standard and custom sizes available
- Gasket rated to 2300°F and is bonded to front panel

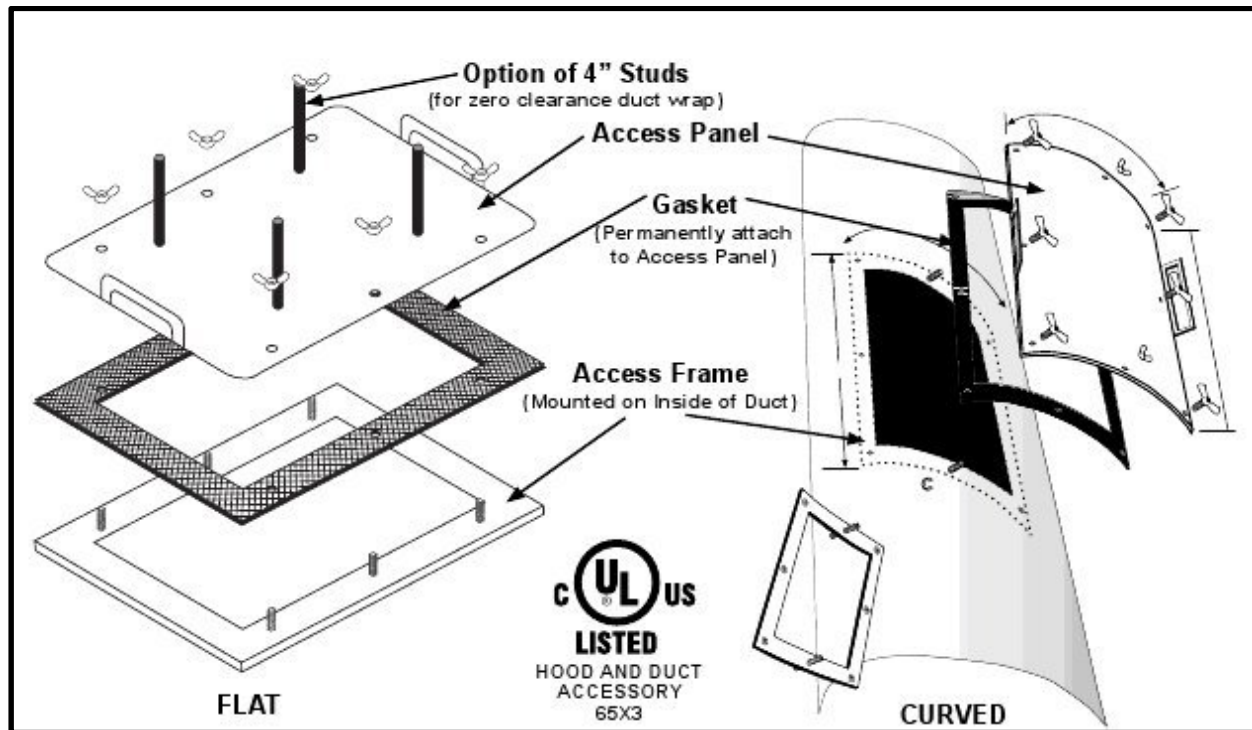

Pricing:

| Flat Access Doors | | Curved Access Doors | |
|-------------------|-----------|---------------------|-----------|
| DS-75071 | \$ 140.00 | DS-750505-C | \$ 216.00 |
| DS-750715 | \$ 160.00 | DS-750511-C | \$ 216.00 |
| DS-750723 | \$ 204.00 | DS-750517-C | \$ 288.00 |
| DS-750606 | \$ 144.00 | DS-750808-C | \$ 220.00 |
| DS-750707 | \$ 140.00 | DS-750811-C | \$ 272.00 |
| DS-750712 | \$ 160.00 | DS-750817-C | \$ 276.00 |
| DS-750720 | \$ 208.00 | DS-750823-C | \$ 284.00 |
| DS-751212 | \$ 188.00 | DS-751117-C | \$ 298.00 |
| DS-751220 | \$ 252.00 | DS-751123-C | \$ 312.00 |
| DS-751620 | \$ 268.00 | DS-751717-C | \$ 298.00 |
| DS-752020 | \$ 272.00 | DS-751723-C | \$ 364.00 |

Flat Doors

UL
LISTED
 HOOD AND DUCT
 ACCESSORY
 65X3
 NFPA #96
 UL FILE No. MH16475

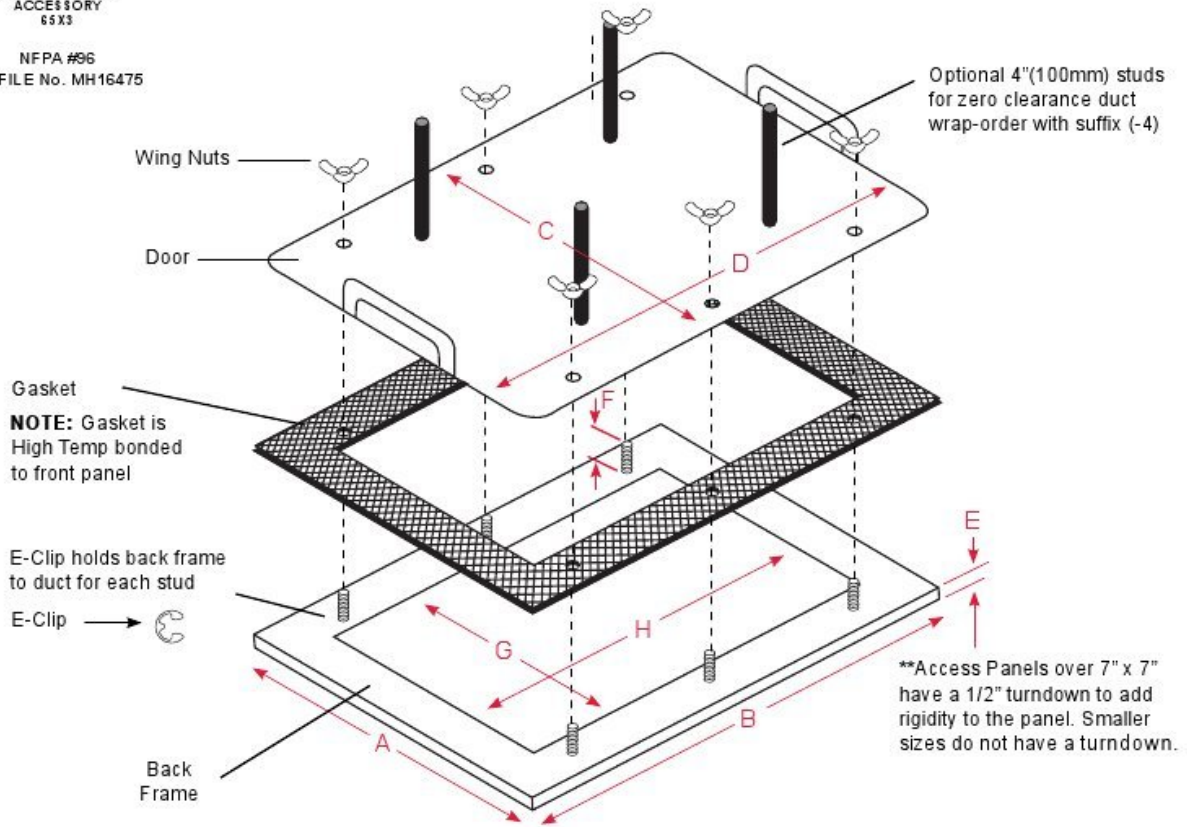

| Please Order by Part No. | BACK FRAME OUTSIDE DIMENSION | | FRONT PANEL OUTSIDE DIMENSION | | PANEL WIDTH | STUD HEIGHT | HOLE SIZE • BACK FRAME INSIDE DIMENSION | | MOUNTING STUDS |
|-----------------------------|---------------------------------|-----------|----------------------------------|----------|----------------|----------------|--|----------|-------------------|
| | A* | B* | C | D | | | G | H | |
| PART NO. | A* | B* | C | D | E | F | G | H | |
| 750710 | 7" | 10" | 7" | 10" | Flat | 1" | 5.5" | 8.5" | 6 |
| 750715 | 7" | 15" | 7" | 15" | Flat | 1" | 5.5" | 13.5" | 6 |
| 750723 | 7" | 23" | 7" | 23" | Flat | 1" | 5.5" | 21.5" | 10 |
| 750606 | 8" | 8" | 8" | 8" | Flat | 1" | 6" | 6" | 4 |
| 750707 | 10" | 10" | 10" | 10" | .5" | 1" | 7" | 7" | 4 |
| 750712 | 10" | 15" | 10" | 15" | .5" | 1" | 7" | 12" | 6 |
| 750720 | 10" | 23" | 10" | 23" | .5" | 1" | 7" | 20" | 10 |
| 751212 | 15" | 15" | 15" | 15" | .5" | 1" | 12" | 12" | 8 |
| 751220 | 15" | 23" | 15" | 23" | .5" | 1" | 12" | 20" | 14 |
| 751620 | 19" | 23" | 19" | 23" | .5" | 1" | 16" | 20" | 16 |
| 752020 | 23" | 23" | 23" | 23" | .5" | 1" | 20" | 20" | 16 |

Curved Doors

UL
LISTED
 HOOD AND DUCT
 ACCESSORY
 86X3

NFPA #96
 UL FILE No. MH16475

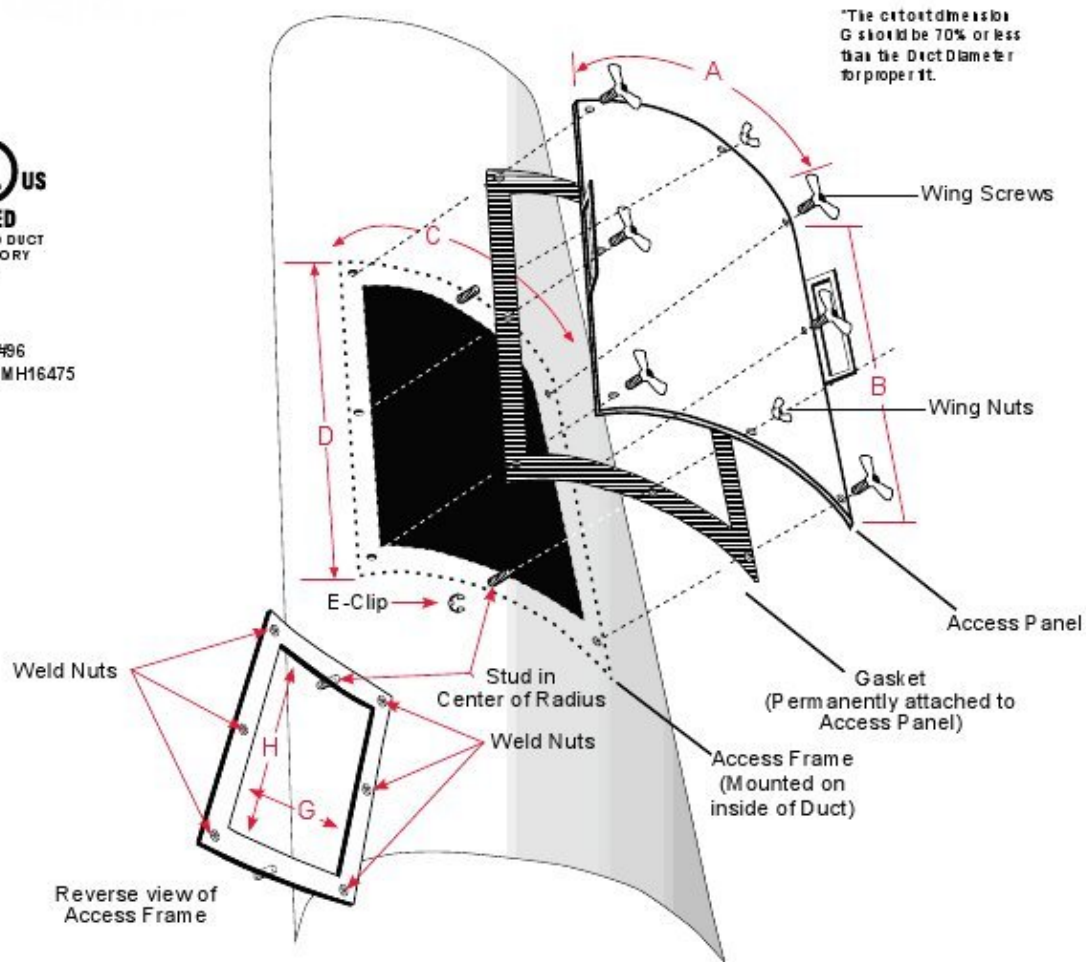

| Please Order by Part No. | OUTSIDE DIMENSIONS | | | | HOLE SIZE INSIDE DIMENSIONS | |
|--------------------------|--------------------|--------|--------|--------|-----------------------------|--------|
| PART NO. | A | B | C | D | G ^a | H |
| 750505-C | 6.56" | 6.75" | 6.56" | 6.75" | 5.06" | 5.25" |
| 750511-C | 6.50" | 12.75" | 6.50" | 12.75" | 5.00" | 11.25" |
| 750517-C | 6.50" | 18.75" | 6.50" | 18.75" | 5.00" | 17.25" |
| 750808-C | 9.50" | 9.75" | 9.50" | 9.75" | 8.00" | 8.25" |
| 750811-C | 9.50" | 12.75" | 9.50" | 12.75" | 8.00" | 11.25" |
| 750817-C | 9.50" | 18.75" | 9.50" | 18.75" | 8.00" | 17.25" |
| 750823-C | 9.50" | 24.75" | 9.50" | 24.75" | 8.00" | 23.25" |
| 751117-C | 12.50" | 18.75" | 12.50" | 18.75" | 11.00" | 17.25" |
| 751123-C | 12.50" | 24.75" | 12.50" | 24.75" | 11.00" | 23.25" |
| 751717-C | 18.50" | 18.75" | 18.50" | 18.75" | 17.00" | 17.25" |
| 751723-C | 18.50" | 24.75" | 18.50" | 24.75" | 17.00" | 23.25" |

Custom Door Quote: Flat Doors

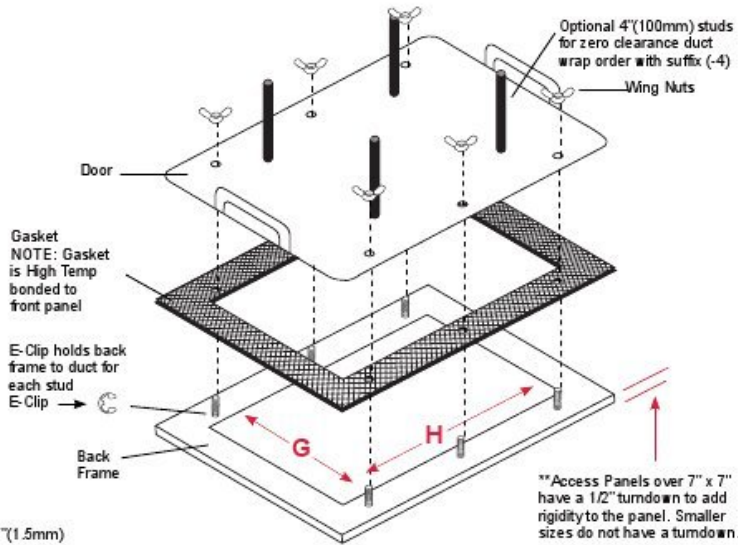

MATERIAL:
 BACK PLATE:
 Cold Rolled Steel, Thickness – 0.057”(1.5mm)
 FRONT PLATE:
 Galvanized Steel, Thickness – 0.060”(1.5mm)

| | |
|--------------------------|--|
| QUANTITY REQUIRED | |
|--------------------------|--|

| DIMENSIONS | SIZE | INCHES or MM |
|---------------|------|--------------|
| DIMENSION "G" | | |
| DIMENSION "H" | | |

| PANEL MATERIAL | Check One |
|----------------------|--------------------------|
| GALVANIZED STEEL | <input type="checkbox"/> |
| STAINLESS STEEL 304 | <input type="checkbox"/> |
| STAINLESS STEEL 316L | <input type="checkbox"/> |

| PANEL THICKNESS | Check One |
|-------------------------------|--------------------------|
| .050" (1.3mm) S/S Models only | <input type="checkbox"/> |
| .060"(1.5mm) | <input type="checkbox"/> |
| .125"(3.2mm) | <input type="checkbox"/> |

| MOUNTING HARDWARE MATERIAL | Check One |
|----------------------------|--------------------------|
| ZINC PLATED STEEL | <input type="checkbox"/> |
| STAINLESS STEEL 304 | <input type="checkbox"/> |
| STAINLESS STEEL 316L | <input type="checkbox"/> |

Additional Notes

| | | |
|---------------|---------------|-------------|
| Date: | P.O. # | Account No: |
| Company Name: | Contact Name: | |
| Address: | City & State: | Zip: |
| Phone No: | E-mail: | |

Custom Door Quote: Curved Doors



NFPA #96
UL FILE No. MH16475

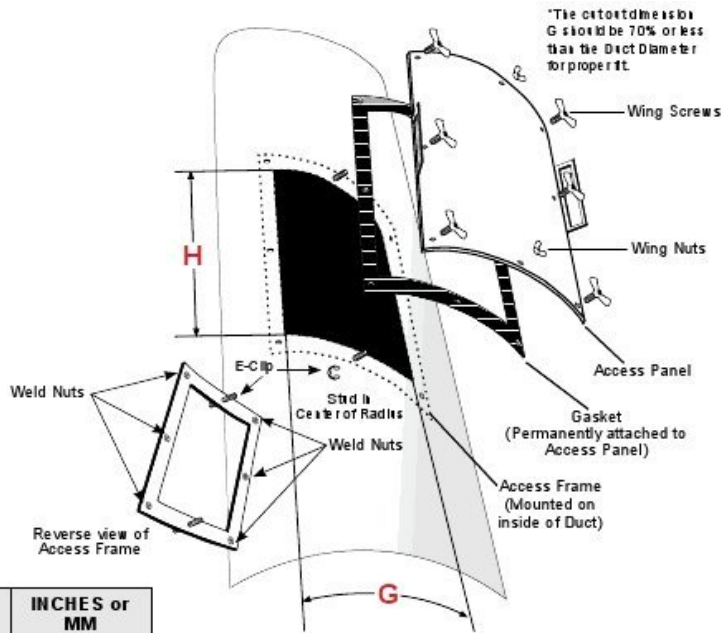

| DIMENSIONS | SIZE | INCHES or MM |
|--|------|--------------|
| DUCT DIAMETER "A" | | |
| CUT OUT DIMENSION "G" "G" = 70% x "A" or LESS | | |
| IF LESS THAN 70% GIVE SIZE | | |
| CUT OUT DIMENSION "H" | | |

NFPA 96 prohibits duct cut out greater than 70% of the duct diameter

| | |
|-------------------|--|
| QUANTITY REQUIRED | |
|-------------------|--|

| PANEL MATERIAL | Check One |
|----------------------|--------------------------|
| GALVANIZED STEEL | <input type="checkbox"/> |
| STAINLESS STEEL 304 | <input type="checkbox"/> |
| STAINLESS STEEL 316L | <input type="checkbox"/> |

| PANEL THICKNESS | Check One |
|-------------------------------|--------------------------|
| .050" (1.3mm) S/S Models only | <input type="checkbox"/> |
| .060" (1.5mm) | <input type="checkbox"/> |
| .125" (3.2mm) | <input type="checkbox"/> |

| MOUNTING HARDWARE MATERIAL | Check One |
|----------------------------|--------------------------|
| ZINC PLATED STEEL | <input type="checkbox"/> |
| STAINLESS STEEL 304 | <input type="checkbox"/> |
| STAINLESS STEEL 316L | <input type="checkbox"/> |

Additional Notes

| | | |
|---------------|---------------|-------------|
| Date: | P.O. # | Account No: |
| Company Name: | Contact Name: | |
| Address: | City & State: | Zip: |
| Phone No: | E-mail: | |